

## Cat.8 S/FTP Patch Cord, LSZH/PVC

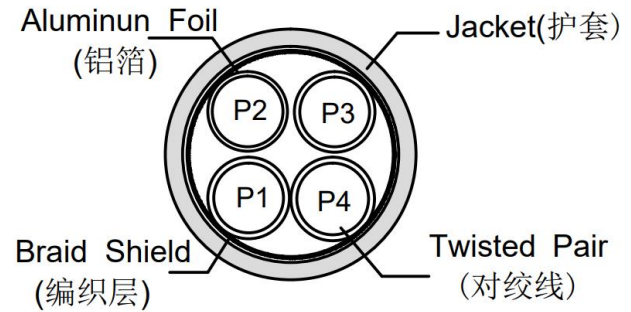

### Technical Specifications

Conductor Material		Stranded Bare Copper
Conductor Number		8C(4 pairs)
Cable AWG		26
Construction( $\pm 0.01\text{mm}$ )		7/0.16
Shield Overlap		aluminum/polyester $\geq 25\%$
Braid Shield 16/5/0.12 Coverage		Aluminum Magnesium Alloy wire $\geq 40\%$
Insulation	Material	SKIN-FOAM- SKIN
	Nom. Thickness(mm)	0.26
	Diameter( $\pm 0.05\text{mm}$ )	1.0
Jacket	Material	LSZH/PVC
	Nom. Thickness(mm)	0.50
	Diameter( $\pm 0.30\text{mm}$ )	6.2

**Product General Description**

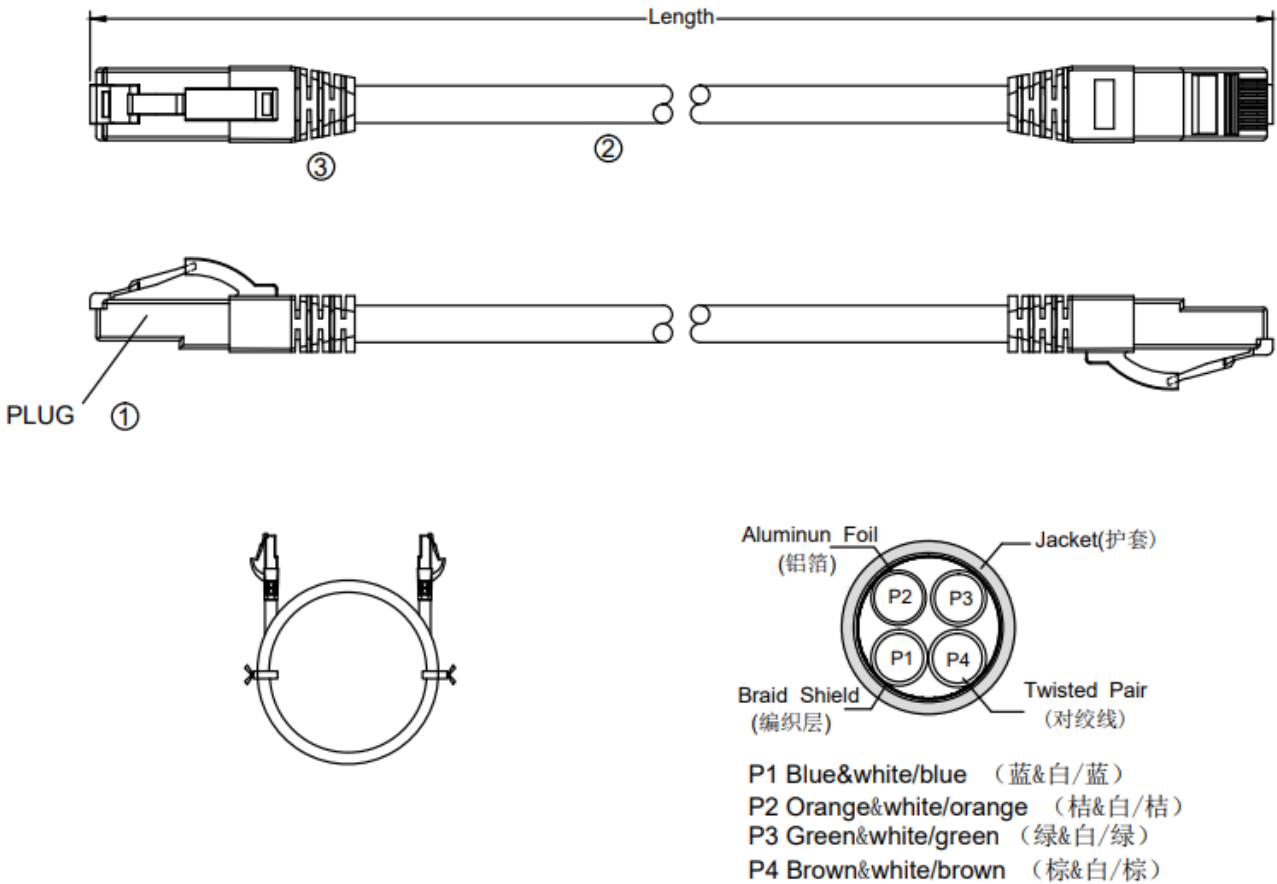

**Pin Assignment: 线位**

Pos. No.	T568B WIRING 568B线位	Pos. No.
1	Orange 桔	1
2	White/Orange 白/桔	2
3	Green 绿	3
6	White/Green 白/绿	6
4	White/Blue 白/蓝	4
5	Blue 蓝	5
7	Brown 棕	7
8	White/Brown 白/棕	8
9	Earth wire 地线	9

- All cable 100% channel testing, point-to-point Fluke test, ISO 11801 channel class1, any open, miswiring, short and intermittent are not permitted.
- After crimping the distance between the bottom of contact and the top surface of plug are 5.90-6.14mm.
- Rohs compliant PVC or PE or LSZH Jacket.
- Installation temperature: -20°C to +75°C
- minimum bending radius: 8D

**For More Information:**

Email: [sales@telex.cn](mailto:sales@telex.cn)    [www.telex.cn](http://www.telex.cn)  
[www.telexcable.com](http://www.telexcable.com)